

Model	Features	Current Draw
CX-94S-12LS	C/W Lock Status Sensor	500 mA @ 12V, 250 mA @ 24V

Warning! SHOCK HAZARD. Care must be taken to keep the power supply and wiring isolated from ground (earth). Use of an ohmmeter to test for shorts is recommended prior to service.

A. 12V DC Input:

Tie the **green and orange** wires together and connect to the ground (-) lead of a 12V DC power source.

Tie the **red and black** wires together and connect to the positive (+) lead.

B. 24V DC Input:

Tie **black and green** wires together, and marrette or tape off.

Connect the ground (-) lead from a 24V DC power source to the orange wire.

Connect the positive (+) lead to the red wire

C. Lock Status Sensor (Reed switch):

The reed switch is rated 0.5 amp @ 30 VDC. DO NOT exceed rated capacity!

Brown = COM

Yellow = NO

Blue = NC

Important!
Power switch should always be wired as shown below in order to minimize the effect of residual magnetism. (Contact Camden for other wiring considerations.)

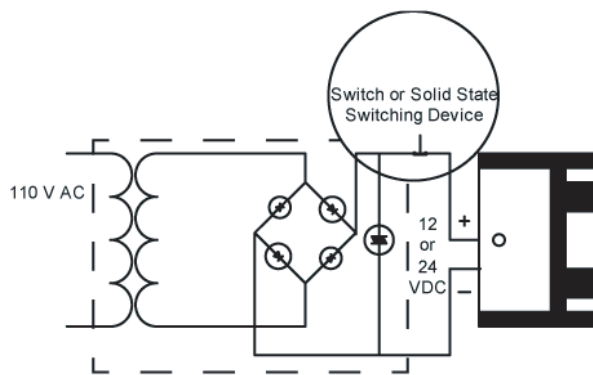

CORRECT

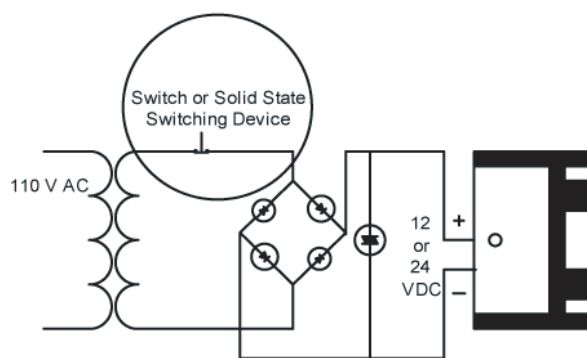

INCORRECT

Important! Please read before installation

- A. Handle the components with care. Damaging the surfaces of the magnet or armature plate may reduce locking efficiency.
- B. The magnet mounts to the gate/door frame. The armature plate must be mounted to the gate/door with the hardware supplied. This allows it to pivot about its center to compensate for door wear and misalignment.
- C. Using diagram below and your own measurements, layout mounting screw locations with the gate/door in its normally closed position.
- D. Mark and drill holes. Install magnet and armature plate with screws installed finger tight at first. Verify all parts align correctly, then firmly tighten screws.

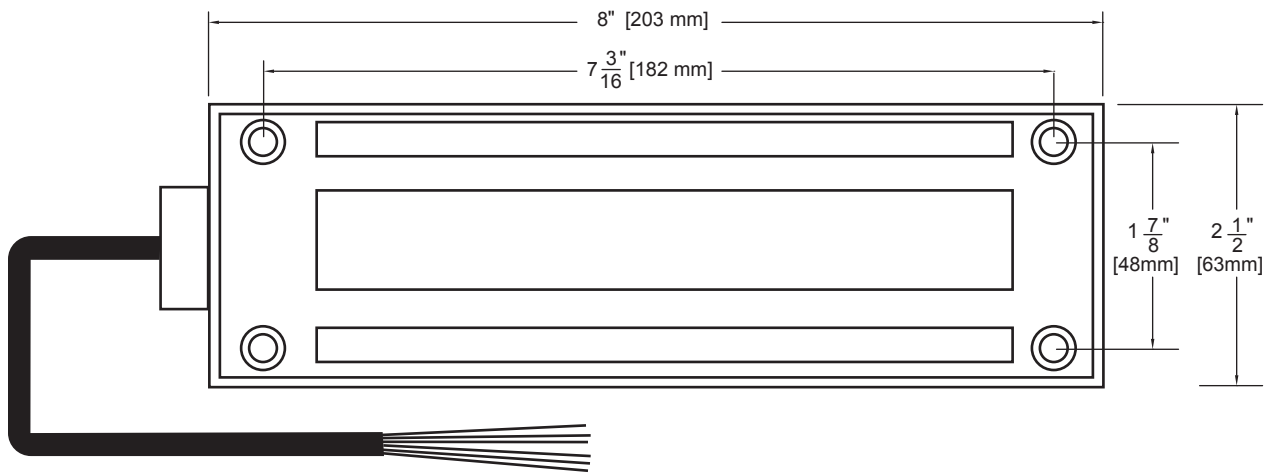

ELECTRO-MAGNETIC GATE LOCK

Questions? Call us toll-free at 1-877-226-3369



Push Buttons



Key Pads



Strikes



Magnetic Locks



Key Switches



Relays & Timers



Access Control